



Digital Manifold

Superheat/Subcooling, Charging/Testing Manifold & Vacuum Gauge Operating Instructions

NOT INTENDED FOR USE ON HAZARDOUS OR CORROSIVE FLUIDS

LOW SIDE DISPLAYS

PRESSURE, SUPERHEAT, TEMPERATURE (T1) and SATURATION TEMPERATURE

PUSH once to toggle between displays

PUSH once to display MAXIMUM, MINIMUM and AVERAGE values of current displays

HOLD DOWN to clear memories

Use Temperature Jack (T1) for Superheat Testing

Uses one or two 9v Alkaline batteries (Two batteries included)
Batteries can be replaced by taking off the back of the box

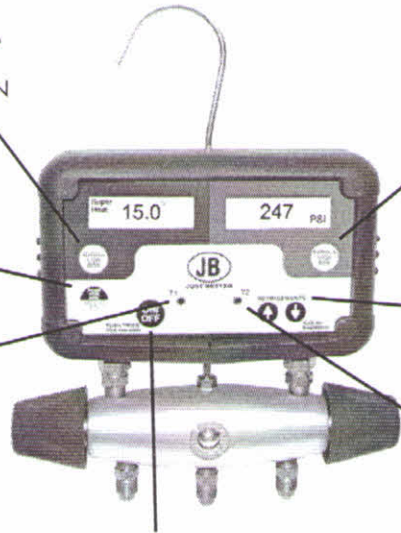

HIGH SIDE DISPLAYS

PRESSURE, SUBCOOLING and

TEMPERATURE (T2), and (T1-T2) DIFFERENCE

PUSH once to toggle between displays

PUSH to select refrigerant (32 available)
HOLD DOWN to change units to Metric or English

Use Temperature Jack (T2) for Subcooling Testing

PUSH once to turn ON or OFF
PUSH twice to select 1 hr/24 hr mode

GAUGE SPECIFICATIONS:

Pressure display range:	29 inHg to 600 psig (-98kPa to 41.34 kPa) (+/- 1 PSI to 200 psi, 0.5% to 600 psi)
Temperature display range:	-40 °F to 200°F (-40 °C to 93°C)
Operating temperature:	-10°F to 120°F (-12 °C to 49°C) (+/- 1°F * 32°F/120 °F; +/- 1.5°F * -10°F/32°F)
Maximum overpressure:	800 psig (5512 kPa)
Battery life and type:	6 Months with two 9v Alkaline battery
Auto-shutoff time:	60 minutes (extended 60 minutes by any button touch) 24 hour mode also available
Refrigerant data source:	NIST REF PROP software and manufacturers data

REFRIGERANT PLUG-IN

The manifold holds up to 32 refrigerants. These are contained in a replaceable plug-in part. This part can be accessed by taking off the back of the box.

A list of refrigerants included with the stock manifold is shown on page 4.

APPLICATION TIPS:

Zero Before Pressure Is Applied

Allow the manifold to Zero at Turn-On: The manifold displays will zero each time the manifold is turned on without pressure. Zeroing the gauge compensates the Pressure display for changes in (1) Altitude and (2) Barometric pressure.

Pressure Calibration

Don't be alarmed if your digital manifold does not agree with your mechanical gauges. The digital manifold is calibrated with a very accurate pressure and is not affected by vibration, motion or position.

Extending On-Time

The digital manifold will turn off automatically after 60 minutes to save battery life. If any button is touched, the

manifold will stay on for another 60 minutes.

The on time can be extended to 24 hours by pushing the ON-OFF button 2 times quickly.

Over/Under-Range Indicator

Pressures or temperatures below or above the rated ranges will cause a "1" to be displayed.

Low Battery Indicator

Low batteries will be indicated by a blinking display and/or faded numbers.

Batteries For Low Temperature Applications

Using standard batteries in low temperature conditions will shorten the life. Change to 9 volt lithium batteries Radio Shack part number 23-665 to get longer life.

CHARGING BY THE SUPERHEAT METHOD

Applies to air conditioning systems with capillary tube or fixed orifice expansion devices.

TARGET SUPERHEAT VALUE

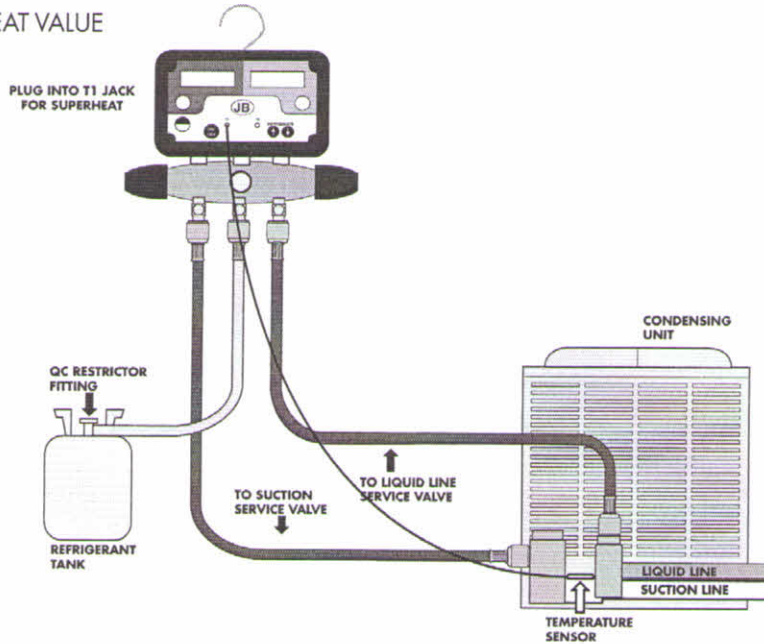

1. Connect the Manifold to the system as shown with the T1 temperature sensor installed on the suction line.
2. Select the system Refrigerant by pushing the refrigerant button of the Manifold until the required refrigerant is shown in the right side display.
3. Put the left side display in the Superheat mode by toggling the Scroll Low Side button.
4. Determine the Indoor Wet Bulb temperature and the Outdoor Dry Bulb temperature.
5. Using the values from Step 4, determine the required superheat from a superheat chart recommended by the system manufacturer. A sample superheat chart is shown below.
6. Very slowly add or remove refrigerant until the Manifold displays the required superheat.

*Sample Superheat Chart
Located on condensing unit.
For older models contact manufacturer*

OUTDOOR TEMP °F	EVAPORATOR ENTERING AIR °F.Wet-Bulb Temperature													
	50	52	54	56	58	60	62	64	66	68	70	72	74	76
55	9	12	14	17	20	23	26.9	29	32	35	37	40	42	45
60	7	10	12	15	18	21	24.3	27	30	33	35	38	40	43
65		6	10	13	16	19	21.9	24	27	30	33	36	38	41
70			7	10	13	16	19.6	21	24	27	30	33	36	39
75				6	9	12	16.2	18	21	24	28	31	34	37
80					5	8	12.2	15	18	21	25	28	31	35
85							12.5	15	18	21	25	28	31	35
90							10.2	13	16	20	24	27	31	35
95								6	10	14	18	22	25	29
100									8	12	15	20	23	27
105									5	9	13	17	22	26
110										6	11	15	20	25
115											8	14	18	23

CHARGING BY THE SUBCOOLING METHOD

Designed For:
13 SEER and other High efficiency Air Conditioning Systems
Large Commercial A/C Rooftop Packages
Refrigeration Systems

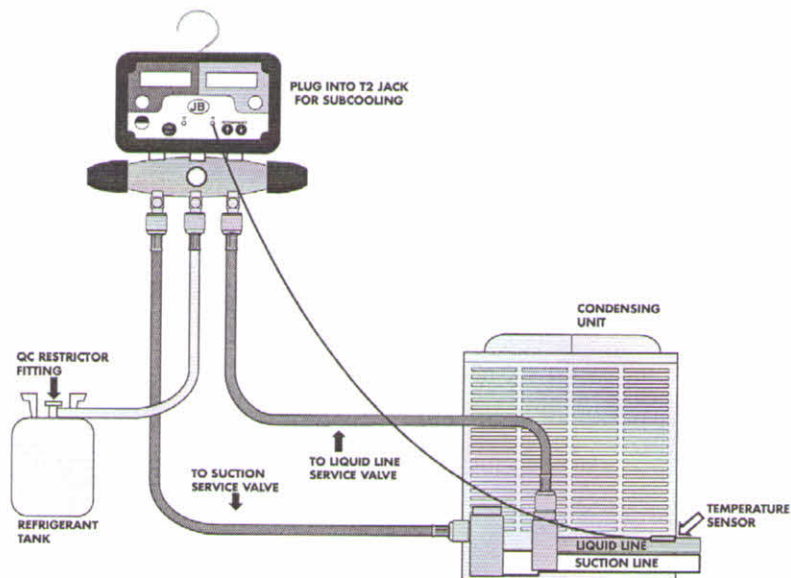

SYSTEMS WITH TXV AND NO RECEIVER

1. Connect the Manifold to the system as shown with the T2 temperature sensor installed on the liquid line.
2. Select the system refrigerant by pushing the refrigerant button of the Manifold until the required refrigerant is shown in the right side display.
3. Put the right side display in the Subcooling mode by toggling the Scroll High Side button.
4. Determine the required subcooling for the system as recommended by the manufacturer or wholesaler. 10°F - 12°F are typical values.
5. Very slowly add or remove refrigerant until the Manifold displays the required subcooling.

13 SEER high efficiency air conditioning systems equipped with a TXV expansion device require a minimum subcooling value to insure solid liquid at the expansion valve. These systems often use the bottom tubes of the condenser as a refrigerant receiver. As a result the amount of refrigerant charge is critical. Too much charge will result in high head pressures during summer operation. Too little charge will cause flash gas in the liquid line and reduce cooling ability.

Pipe as shown with a temperature sensor on the liquid line. Toggle to Subcooling using the Scroll High Side button to display the subcooling value. Very slowly add or remove refrigerant to obtain the manufacturers target subcooling value. Allow the system to stabilize for 20 minutes after adding or removing refrigerant charge before retesting for subcooling.

Many manufacturers use 10°F subcooling as an acceptable value but the actual subcooling value must take into account the fact that the liquid refrigerant at the TXV must be solid liquid. The liquid line vertical rise and the long liquid line runs will also affect the required subcooling. See the system manufacturers instructions for the amount of subcooling required to compensate for these installation situations.

SYSTEM APPLICATIONS

- Use for Thermostat controlled supermarket cases and coolers by monitoring the Average temperature. By this method, obtain the most accurate Thermostat setting.
- Use the High and Low pressure display to accurately set the low pressure cut-in and cut-out values for pressure controlled cases and coolers.
- Apply the two temperature sensors, with the Manifold toggled to show the T1-T2 Differential temperature, to measure temperature drop across a cooling coil.
- Use a wet sock over a temperature sensor to measure the Wet Bulb temperature.

A/C & REFRIGERATION APPLICATIONS

Contact your TXV manufacturer for the exact superheat adjust rate.

CHECKING TXV SETTING

The objectives of the TXV superheat setting is to prevent liquid refrigerant floodback to the compressor and to optimize system operation by the use of a selected setting.

The two temperature method of measuring superheat is not recommended because it can produce a wrong superheat measurement, due to the effect of temperature glide of the blended refrigerants and variations in evaporator pressure drop.

NEW RESIDENTIAL A/C SYSTEMS

For new installations of residential A/C systems, the pre-charge will not provide an accurate amount of refrigerant charge because of the variation in the length of liquid and suction line connecting to the "A" coil.

RETROFITTING SYSTEMS

Retrofitting systems to a new refrigerant can change the TXV superheat setting. The superheat setting should be checked before and after retrofitting to be sure the superheat is right for the equipment.

AVAILABLE REFRIGERANTS

R11	R402B	R413A
R12	R403B	R414B
R13	R404A	R416A
R22	R406A	R417A * New addition
R23	R407A	R422A
R134A	R407B	R422B * New addition
RB276	R407C	R500
R290	R408A	R502
R401A	R409A	R507
R401B	R410A	R508B
R402A	R411C	

SET SUPERHEAT FOR "HUNTING" TXV VALVES

In refrigeration and air conditioning systems, the expansion valve often operates to produce an evaporator superheat which constantly swings up and down in value, called "hunting." The DM-2 provides the "Average" superheat value to use for TXV valve adjustment.

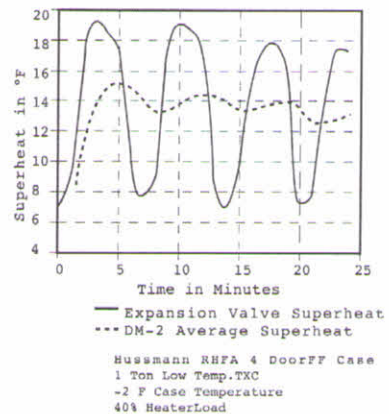

REPLACEMENT ITEMS

PART NO.	DESCRIPTION
SH-56	Socks (5)

ACCESSORIES

SH-59	6' Temperature Sensor Clamp w/ right elbow (made for DM)
SH-60	6' Temperature Sensor w/ right elbow (made for DM)

Warranty Information:

Unit has 1 year over the counter warranty due to manufacturing defects with proof of purchase. Customer abuse not related to manufacturing quality will void warranty.

